

The QuadTech 1865 as a Current Meter

The 1865 Megohmmeter / IR Meter consists (as all megohmmeters do) of a voltage source and a current meter. The 1865 instrument allows for selection of the display of current or resistance rather than just the display of resistance. This means that it is possible to use the instrument as a precision micro amp (μA) meter even when the voltage source is other than the internal voltage supply. Figure 1 illustrates two methods of connecting to the 1865 instrument to a voltage supply.

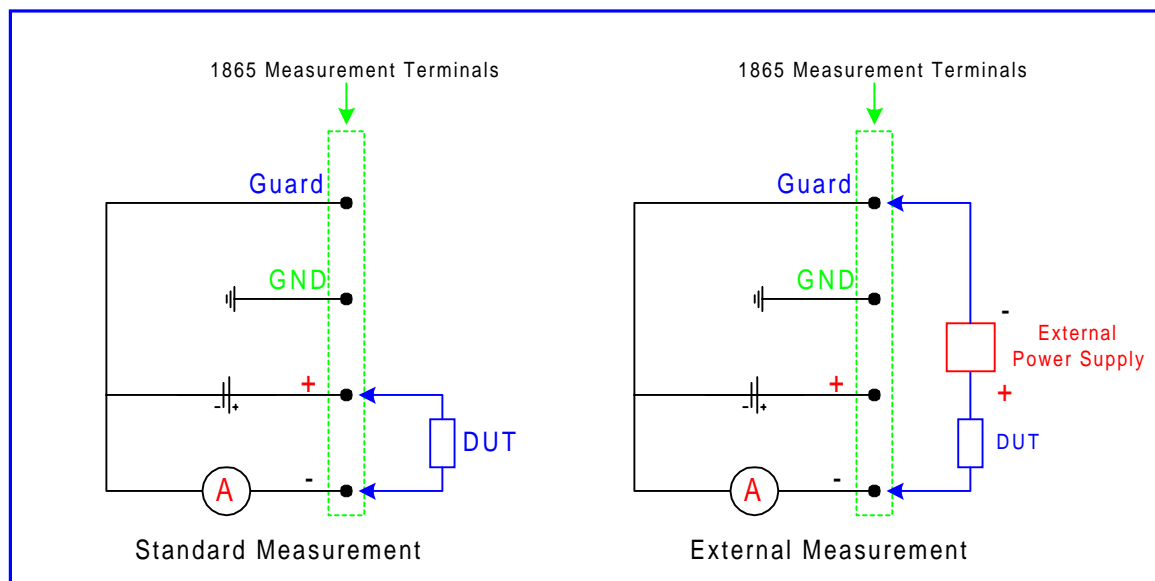

Figure 1: Standard & External Measurement Configuration

Using the internal supply is the normal mode for measuring leakage current of any device or material. Using an external supply becomes useful for measuring leakage of capacitors. This method allows the use of power supplies with higher current and voltage than is available from the 1865 instrument. The External method is also used when the current is generated from the DUT itself. As an example, some nuclear probes generate small currents and this is a good method to measure the current or to calibrate the probes.

Example External Connections

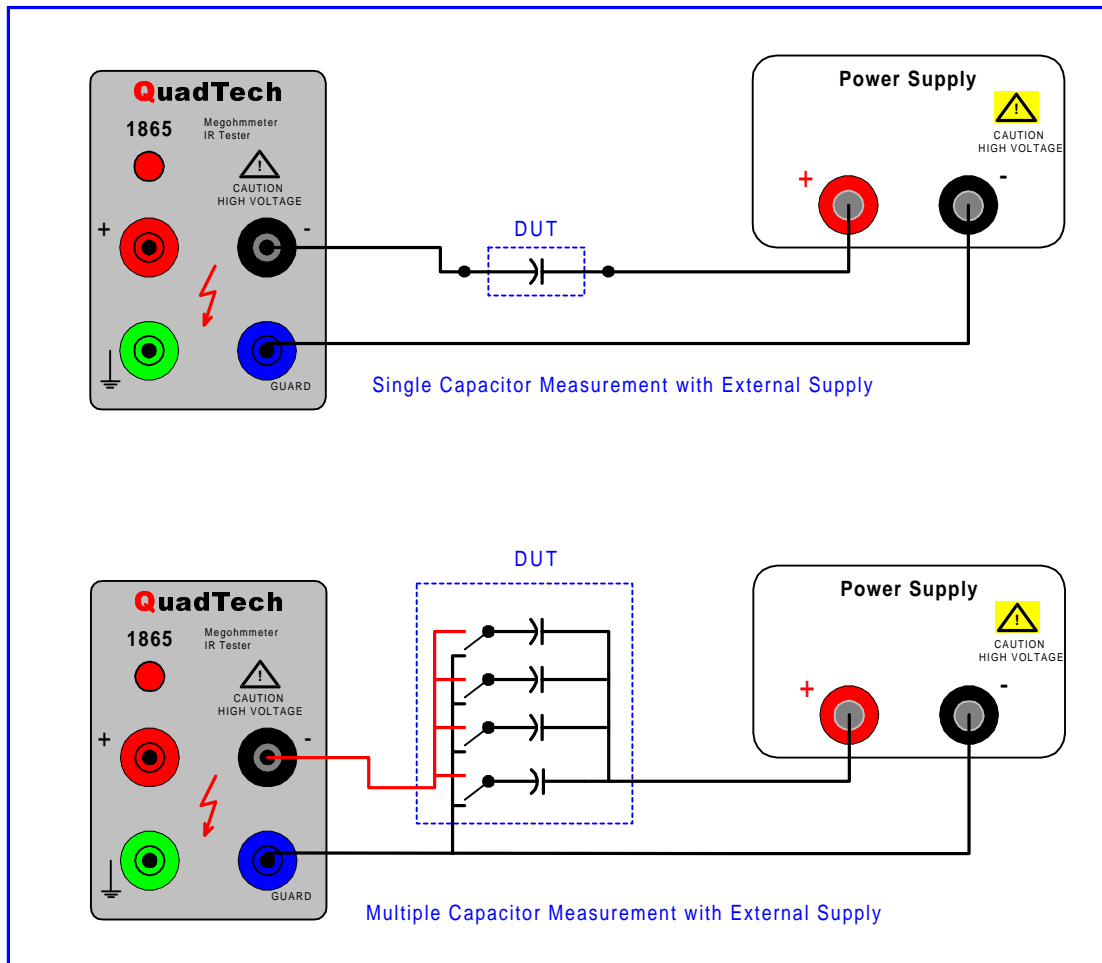

Figure 2: Example Applications

For safety reasons, the 1865 power supply is limited to 2mA and 1000V. When measuring the leakage of capacitors these limitations create a very long charge time and therefore a long measurement time. By using an external supply, the charge current or voltage can be increased to reach a charged condition much more rapidly. **NOTE:** If this approach is used, great care should be taken in ascertaining the safety of the operator.

For complete product specifications on the 1865 Megohmmeter/IR Tester or any of QuadTech's products, visit us at <http://www.quadtech.com/resources/dataindex.html>. Do you have an application specific testing need? Call us at 1-800-253-1230 or email engineering at rroetzer@quadtech.com and we'll work with you on a custom solution. Put QuadTech to the test because we're committed to solving your testing requirements.

The information presented here is subject to change and is intended for general information only

©QuadTech, Incorporated

Telephone: 1- 800-253-1230, Website: <http://www.quadtech.com>

Printed in U.S.A.

P/N 035031

December 2000